

PROSPETTO APERTO scala 1:10

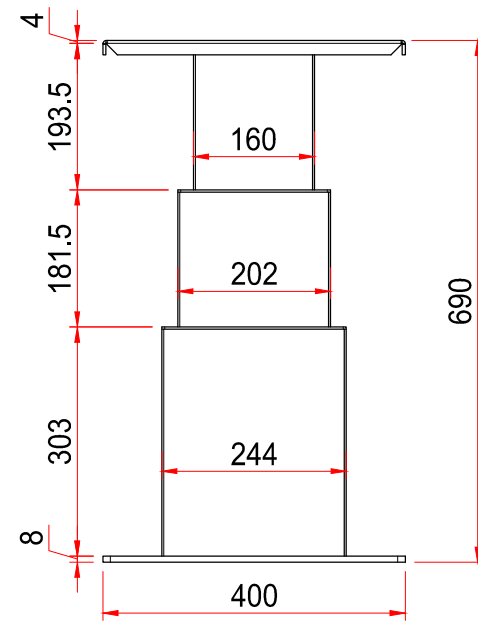

PROSPETTO CHIUSO scala 1:10

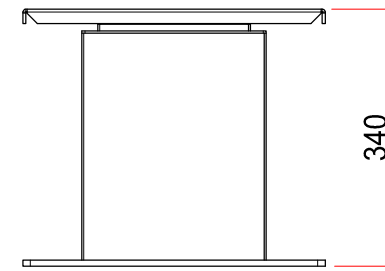

PIANTA scala 1:10

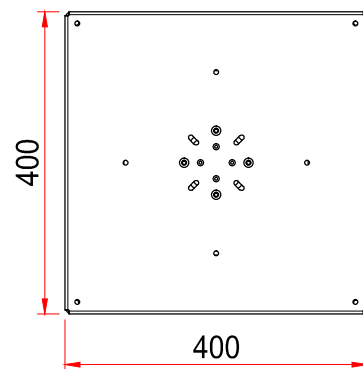

VISTE ASSONOMETRICHE scala 1:10

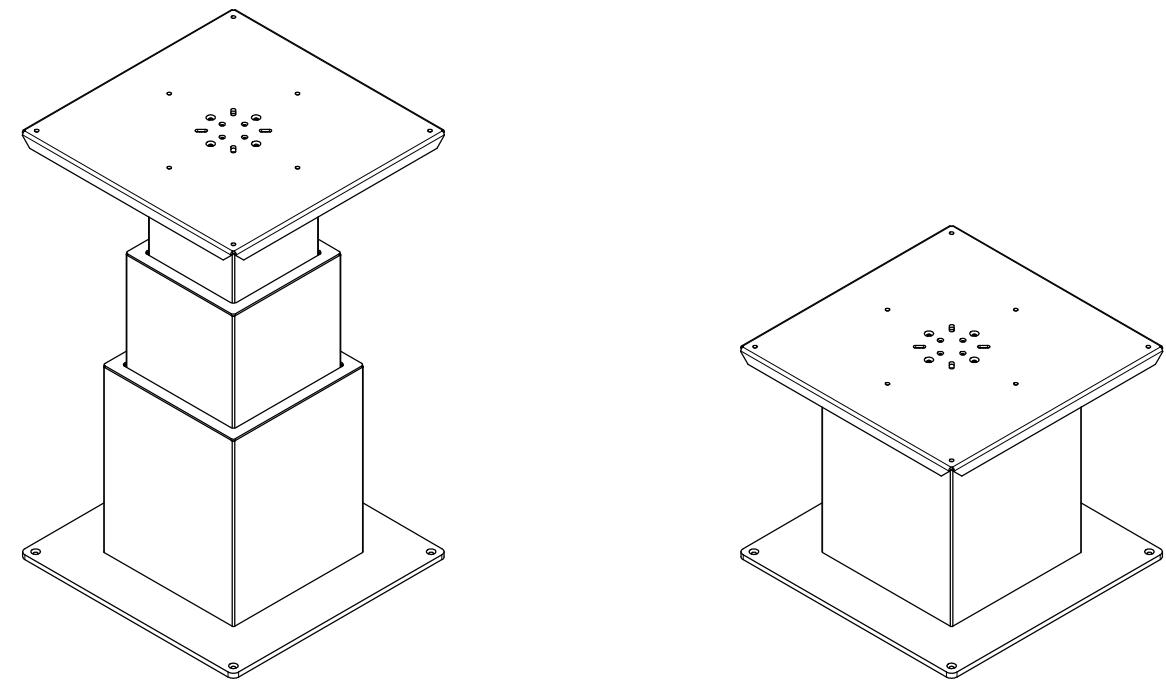

Supporto tavolo elett. quadrato 3 stadi



IL PRESENTE DISEGNO E' DI PROPRIETA' AZIENDALE. E' PROIBITA LA RIPRODUZIONE O LA CONSEGNA A TERZI. L'AZIENDA TUTELERA I PROPRI DIRITTI A TERMINI DI LEGGE

V4	-	-	
V3	-	-	
V2	-	-	
Codice Interno Internal Code	-	Disegnato Drawn by	
Versione Disegno Drawing Version	V1	Codice Cliente Client Code	20.18898A/INOX
Scala Scale	1:10	Materiale Material	INOX 316
Data Date	24/09/2018	Dimensioni Dimensions	mm

